

TRENCH BACKFILL REQUIREMENTS:

1. PROPOSED STREETS- REFER TO DETAIL TB-1 OF SECTION 31 FOR BACKFILL REQUIREMENTS ABOVE THE PIPE ZONE.
2. EXISTING STREETS- REFER TO DETAIL TB-1 AND TB-3 OF SECTION 31 FOR BACKFILL REQUIREMENTS ABOVE THE PIPE ZONE.

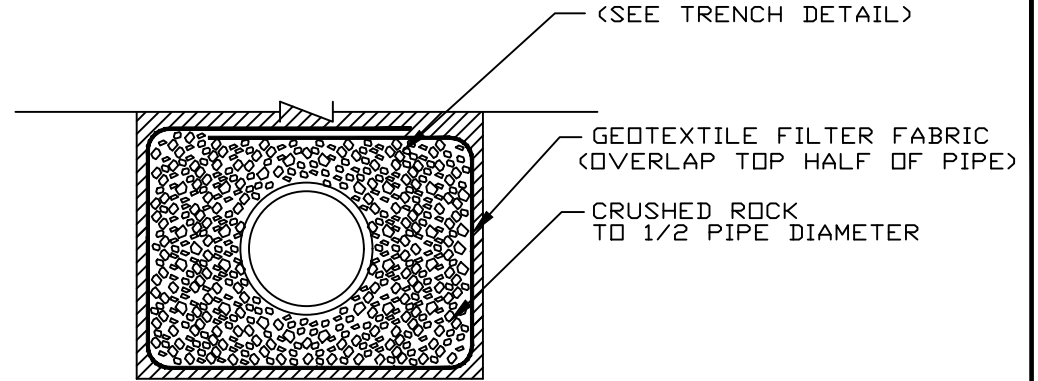
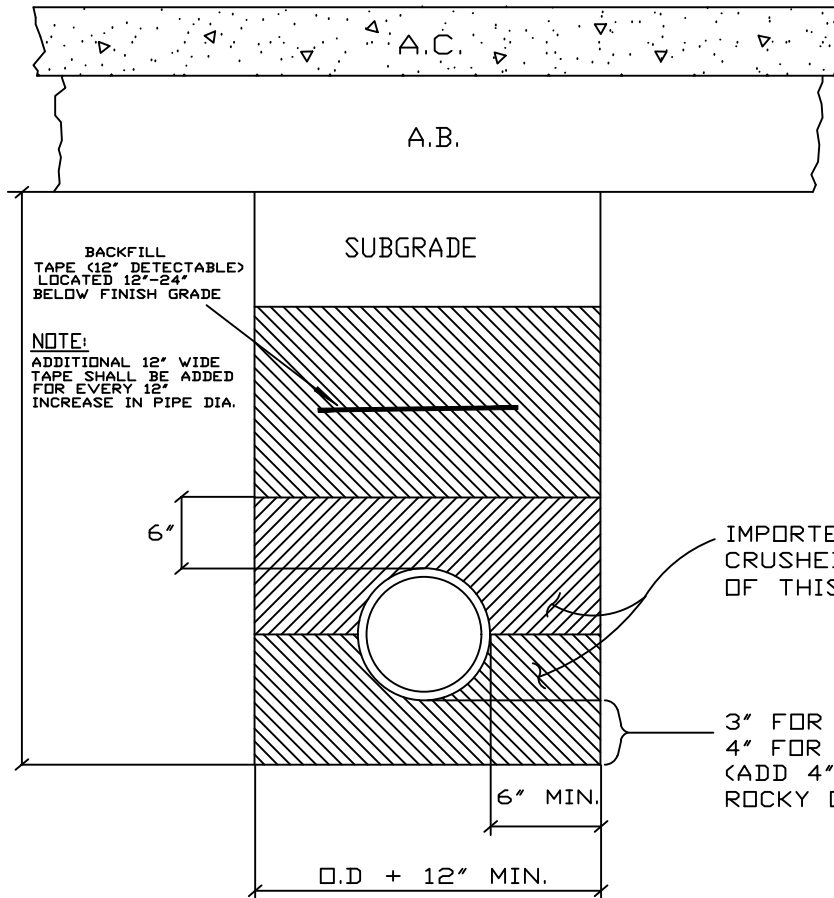

SATURATED PIPE TRENCH

IMPORTED MATERIAL 1/2" OR 3/4" CRUSHED ROCK PER SECTION 71-5.L. OF THIS STANDARD

3" FOR UNDER 12" PIPE
4" FOR 12" OR LARGER PIPE
(ADD 4" TO THE EXCAVATION IN ROCKY OR UNYIELDING SOIL)

Richard D. Plecker

RICHARD PLECKER
ENVIRONMENTAL UTILITIES DIRECTOR

	ENVIRONMENTAL UTILITIES DEPARTMENT
	SEWER MAIN TRENCH AND BACKFILL

SCALE: NONE
REVISED: JANUARY 2019
DRAWN BY: R. VAN NESS
APPROVED BY: RICHARD PLECKER

SS-1

NOTE: BACKFILL SHALL BE MECHANICALLY CONSOLIDATED OR SHOVEL SLICED UNDER THE HAUNCHES OF THE PIPE

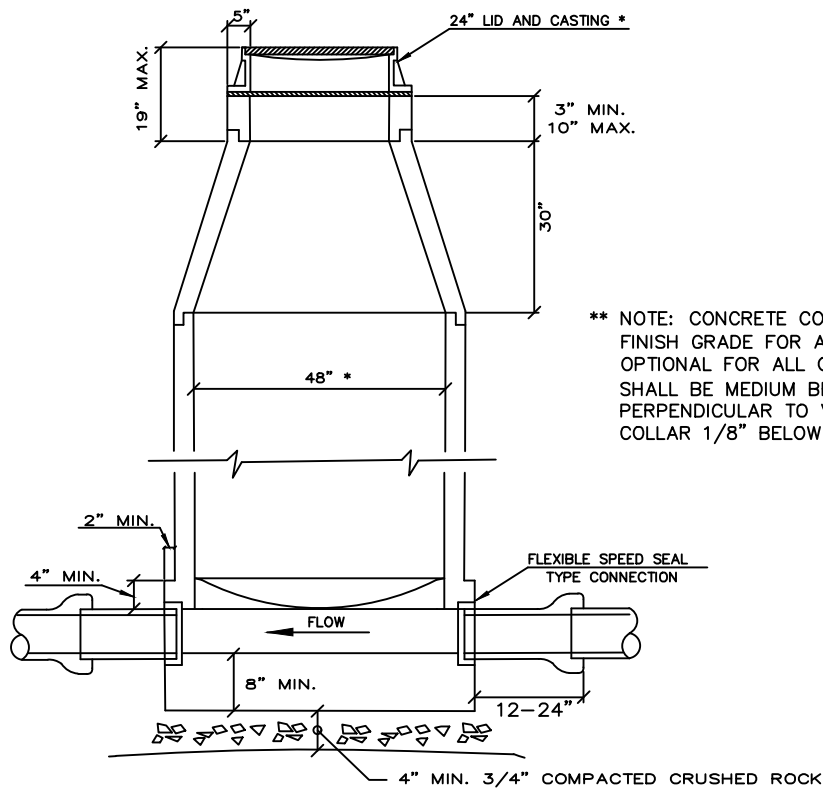
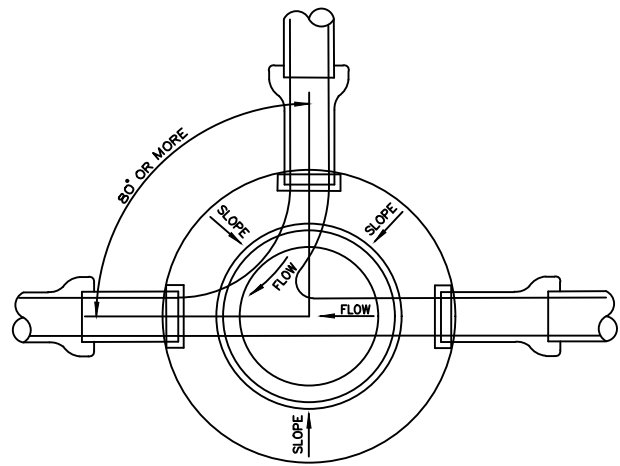

NOTES

MANHOLE LIDS SHALL BE SEALED WITH AN APPROVED RUBBER GASKET.

JOINTS SHALL BE MORTARED INSIDE AND OUT.

UNUSED CHANNELS SHALL BE COMPLETELY FILLED WITH GROUT.

STUBS SHALL BE PLUGGED AND END MARKED ABOVE FINISHED GRADE WITH A REDWOOD 4 BY 4 POST PAINTED GREEN IF AN ECCENTRIC CONE IS USED, PLACE SUCH THAT THE OPENING IS OVER THE UPSTREAM INVERT.

NO CAULDER OR REPAIR COUPLINGS SHALL BE USED ON NEW CONSTRUCTION

FLOW LINES SHALL HAVE A 1/10 DROP OR AS INDICATED ON PLANS

MANHOLES WITH DROPS SHALL BE EPOXY COATED. THE COATING SHALL BE APPLIED PER SEC. 91-10K OF THESE STANDARDS.

* 60" & 72" MANHOLES SHALL USE A 36" COMPOSITE LID AND FRAME,

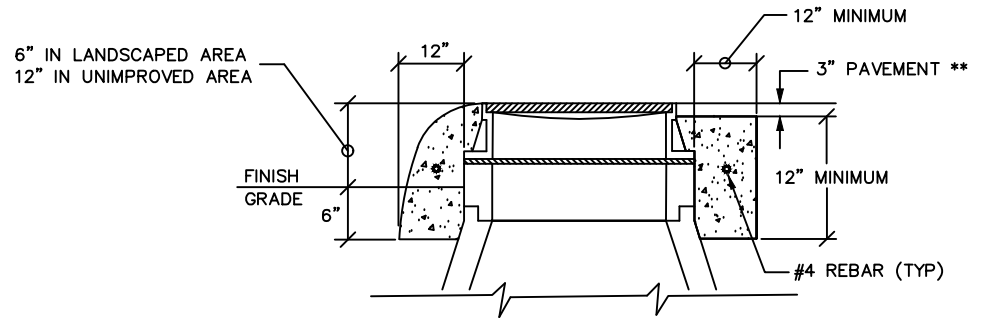

CONCRETE COLLAR DETAIL

** NOTE: CONCRETE COLLAR SHALL BE PLACED FLUSH TO FINISH GRADE FOR ALL COLLECTORS AND ARTERIALS, OPTIONAL FOR ALL OTHER ROADWAYS. FINISH SURFACE SHALL BE MEDIUM BROOM FINISH WITH PATTERN PERPENDICULAR TO VEHICLE TRAVEL DIRECTION. SET COLLAR 1/8" BELOW ADJACENT FINISHED PAVEMENT.

Richard D. Plecker

RICHARD PLECKER
ENVIRONMENTAL UTILITIES DIRECTOR

CITY OF
ROSEVILLE
CALIFORNIA

ENVIRONMENTAL UTILITIES
DEPARTMENT

SEWER MANHOLE STANDARD 48 INCH

SCALE: NONE
REVISED: JANUARY 2020
DRAWN BY: R. VAN NESS
APPROVED BY: RICHARD PLECKER

SS-2

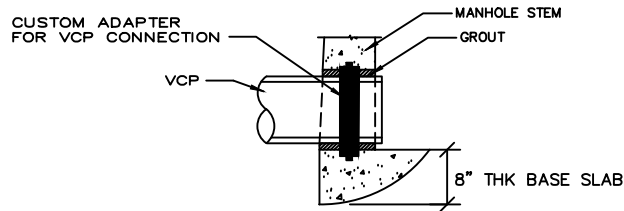
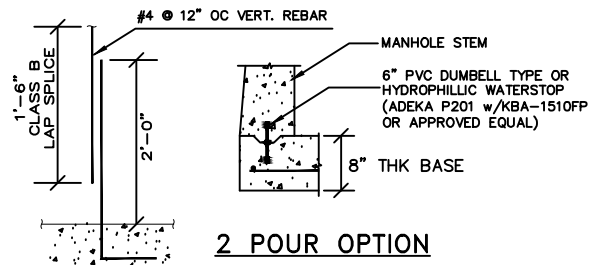

PIPE DIA	MANHOLE DIA, D"
6" THRU 12"	4'-0"
24" THRU 36"	5'-0"

* MANHOLE BASE DIMENSIONS FOR PIPE DIA. LARGER THAN 36" TO BE DESIGN BUILT. CONTRACTOR TO MODIFY THE DESIGN FOR BUOYANCY AS NEEDED FOR HIGH GROUND WATER, DEEP MANHOLE BASE APPLICATION.

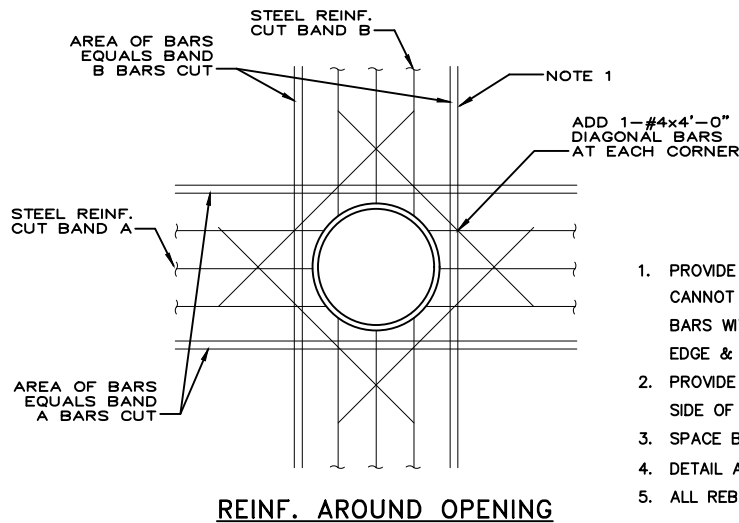
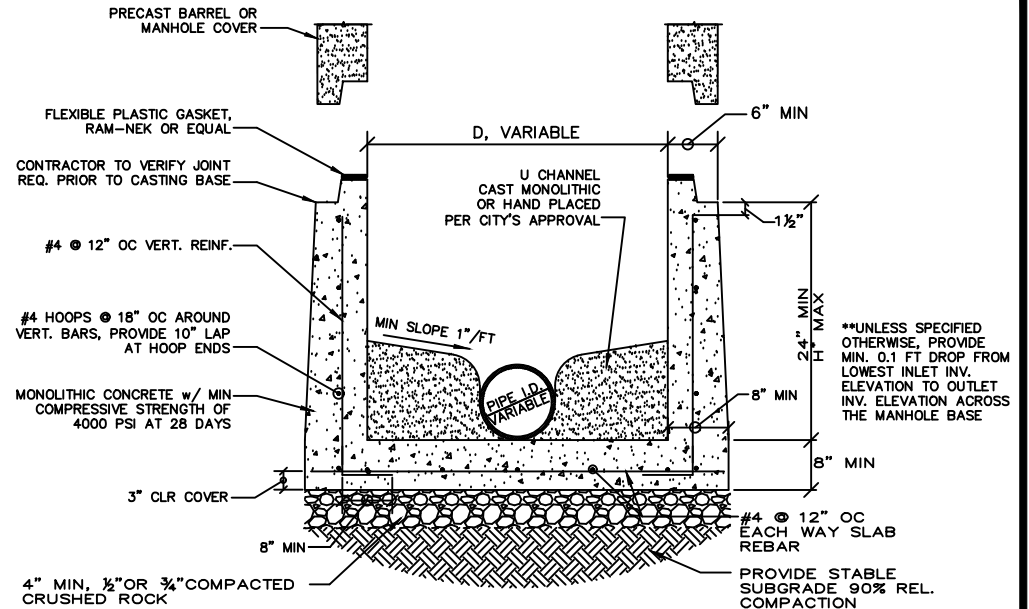

1. PROVIDE MINIMUM LAP LENGTH, WHERE FULL LAP LENGTH CANNOT BE ACHIEVED DUE TO THE SLAB, TERMINATE BARS WITH A STANDARD 90° BEND, 2" CLEAR OF SLAB EDGE & BOTTOM.
2. PROVIDE A MIN OF 2"A" BARS AND 2"B" BARS EACH SIDE OF THE OPENING.
3. SPACE BARS AT 3*DIAMETER OR 3" MIN. ON CENTER
4. DETAIL APPLIES TO PIPE OPENINGS > 9" DIAMETER
5. ALL REBAR TO BE GRADE 40 KSI REINFORCING STEEL

Richard D. Plecker

RICHARD PLECKER
ENVIRONMENTAL UTILITIES DIRECTOR

CITY OF
ROSEVILLE
CALIFORNIA

ENVIRONMENTAL UTILITIES
DEPARTMENT

**SEWER MANHOLE
CAST-IN-PLACE BASE**

SCALE: NONE
REVISED: SEPTEMBER 2022
DRAWN BY: J. THOMPSON
APPROVED BY: RICHARD PLECKER

SS-2A

GENERAL NOTES:

1. ALL SERVICE LINES SHALL BE 4" FOR RESIDENTIAL AND 6" FOR COMMERCIAL UNLESS OTHERWISE NOTED.
2. SERVICES SHALL HAVE SAME BEDDING AND BACKFILL AS LATERAL SEWER.
3. CONTRACTOR SHALL USE THE MOST APPROPRIATE TYPE CONNECTION (A OR B) FOR THE PARTICULAR SITUATION ENCOUNTERED.
4. SERVICE SEWER SHALL HAVE MINIMUM 3'-0" COVER AT PROPERTY LINE WHENEVER LATERAL DEPTH AND SERVICE SEWER SLOPE OF 1/4" PER FOOT (MINIMUM) PERMIT. SEE NOTE 10.
5. WHEN THE LATERAL SEWER DEPTH IS SUCH THAT MINIMUM COVER AT PROPERTY LINE CANNOT BE MET, THE MINIMUM SLOPE OF 1/4" PER FOOT SHALL GOVERN THE COVER.
6. MIN. SPECIFIED COVER AT THE PROPERTY LINE SHALL BE MEASURED FROM EXISTING GROUND SURFACE OR EDGE OF ADJACENT ROADWAY, WHICHEVER IS LOWER.
7. A SPECIFIC ELEVATION AT THE PROPERTY LINE, WHEN SHOWN ON THE PLANS OR DESIGNATED BY THE ENGINEER, SHALL GOVERN.
8. MITER FITTING SHALL BE MAX. 45°.
9. MINIMUM DEPTH OF COVER SHALL BE INCREASED TO 4'-6" WHERE A WATER MAIN IS TO BE INSTALLED AT BACK OF SIDEWALK AS PART OF THE SUBDIVISION IMPROVEMENTS. IN SUCH CASES, THE SERVICE SHALL BE EXTENDED TO A MINIMUM OF 7' BACK OF SIDEWALK; CLEANOUT TO GRADE SHALL REMAIN WITHIN 3' OF BACK OF SIDEWALK.
10. SEWER SERVICES ORIGINATING FROM SEWER MAINS 14 FT AND GREATER IN DEPTH SHALL HAVE THE CROTCH OF THE VCP "WYE" FITTING FILLED WITH CONCRETE.
11. UNDERGROUND CONTRACTOR SHALL END SEWER SERVICE 2-3' UPSTREAM OF SEWER CLEANOUT. SEE STANDARD DETAIL SS-5.

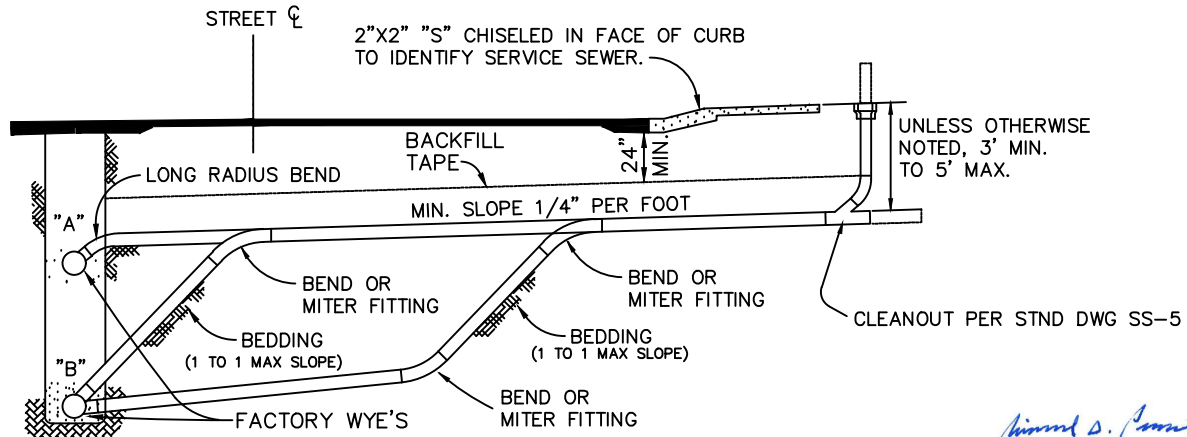

ELEVATION

Richard D. Plecker

RICHARD PLECKER
ENVIRONMENTAL UTILITIES DIRECTOR

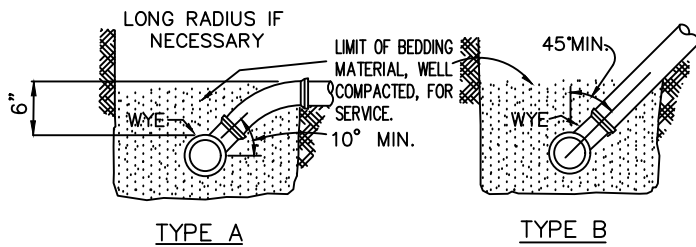

CONNECTION DETAILS



ENVIRONMENTAL UTILITIES
DEPARTMENT

SEWER SERVICE

SCALE: NONE
REVISED: JANUARY 2017
DRAWN BY: R. VAN NESS
APPROVED BY: RICHARD PLECKER

SS-4

NOTES:

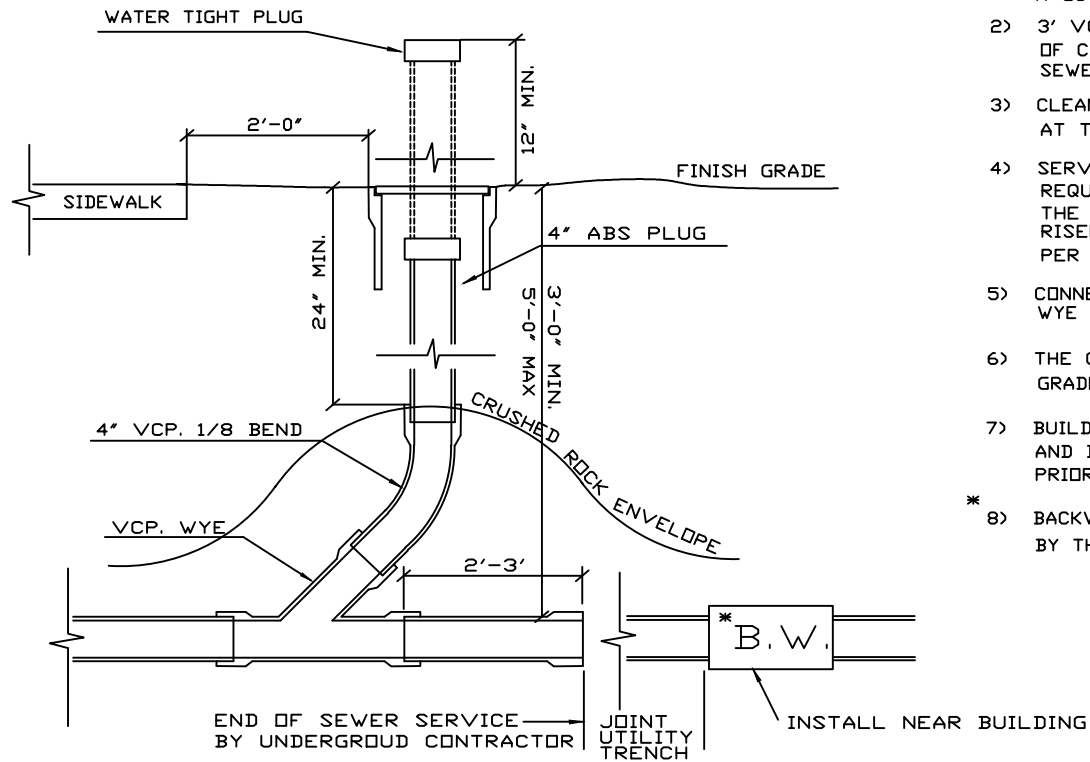

- 1) INSTALL ROUND NON-TRAFFIC TYPE CONCRETE VALVE BOX & COVER MARKED "SEWER" IN A NON - TRAFFIC AREA . INSTALL METAL LID MARKED "SEWER" IN AREAS WITH POTENTIAL TRAFFIC. A G5 BOX SHALL BE INSTALLED IN TRAFFIC AREAS.
- 2) 3' VCP STUB SHALL BE INSTALLED UPSTREAM OF CLEANOUT. 2' VCP SHALL BE INSTALLED WHERE SEWER SERVICE ENTERS OVER JOINT UTILITY TRENCH
- 3) CLEANOUT BOX TO BE FREE OF ALL DIRT AND READY AT TIME OF PRE-FINAL INSPECTION.
- 4) SERVICES OVER 100' LONG AND COMMERCIAL SERVICES REQUIRE A MIN. 6' CLEANOUT WITH 6" FITTINGS. THE CLEANOUT BOX SHALL BE A G-5 BOX FOR 4" - 6" RISERS AND A G-12 BOX FOR 8" RISERS. CONSTRUCT PER W-16.
- 5) CONNECTION TO MAIN SHALL BE WITH A FACTORY WYE OR AT A MANHOLE.
- 6) THE CLEANOUT RISER SHALL BE INSTALLED 12" ABOVE GRADE PRIOR TO BUILDING CONSTRUCTION.
- 7) BUILDING CONTRACTOR SHALL SET BOX TO FINISH GRADE AND INSTALL AN ABS PLUG SET 6" BELOW THE SURFACE PRIOR TO BUILDING PRE-FINAL.
- * 8) BACKWATER VALVE IF REQUIRED SHALL BE INSTALLED BY THE BUILDING CONTRACTOR

- 9) TREES ARE TO BE PLACED 7 1/2' FROM CLEAN OUT.
- 10) INSTALL A CITY CLEANOUT AT A MINIMUM 5' FROM COMMERCIAL BUILDINGS.

Richard D. Plecker
 RICHARD PLECKER
 ENVIRONMENTAL UTILITIES DIRECTOR

	ENVIRONMENTAL UTILITIES DEPARTMENT
SEWER SERVICE CLEANOUT	
SCALE: NONE REVISED: JANUARY 2020 DRAWN BY: R. VAN NESS APPROVED BY: RICHARD PLECKER	
SS-5	

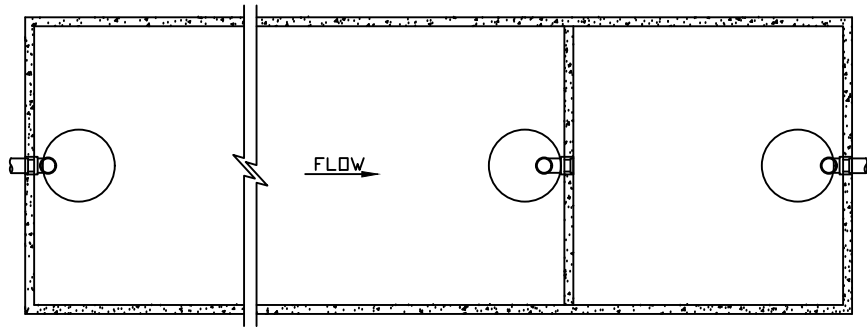

TOP VIEW

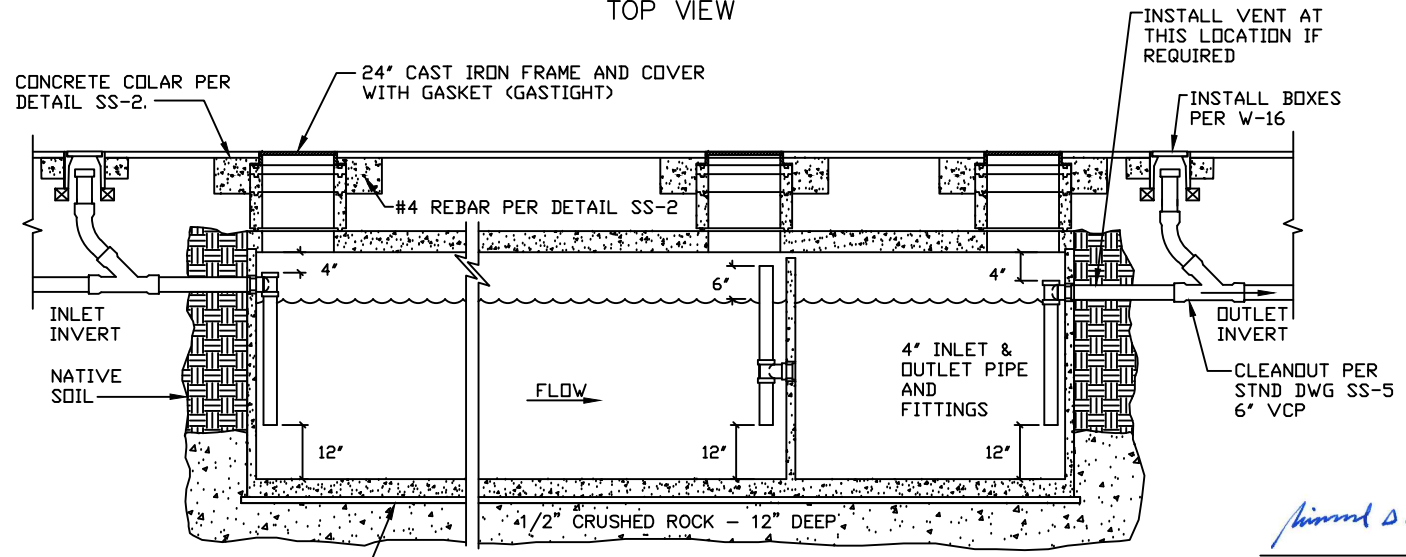

SIDE VIEW (CUT AWAY)

MIN. BOX DESIGN LOAD: H-20 TRAFFIC

Richard D. Plecker

RICHARD PLECKER
ENVIRONMENTAL UTILITIES DIRECTOR

*NOTE: THE PRECAST CONCRETE UNITS SHALL BE PLACED ON LEVEL UNDISTURBED SOIL, W/1/2" CRUSHED ROCK 12" DEEP. TWO 2x6 REDWOOD GRADE BOARDS SHALL BE PLACED BELOW THE TANK SIDE WALLS ALONG THE LONG DIMENSION PER THE MANUFACTURERS GUIDELINES.

SIZING SHALL BE BASED ON THE CALIFORNIA PLUMBING CODE

*NOTE: PRIOR TO BACKFILL, INTERCEPTOR SHALL BE FILLED WITH WATER AND HELD FOR 24HRS WITH NO VISIBLE LEAKAGE.

	ENVIRONMENTAL UTILITIES DEPARTMENT
--	---------------------------------------

GREASE INTERECEPTOR (TYP.)

SCALE: NONE
 REVISED: JANUARY 2017
 DRAWN BY: R. VAN NESS
 APPROVED BY: RICHARD PLECKER

SS-6

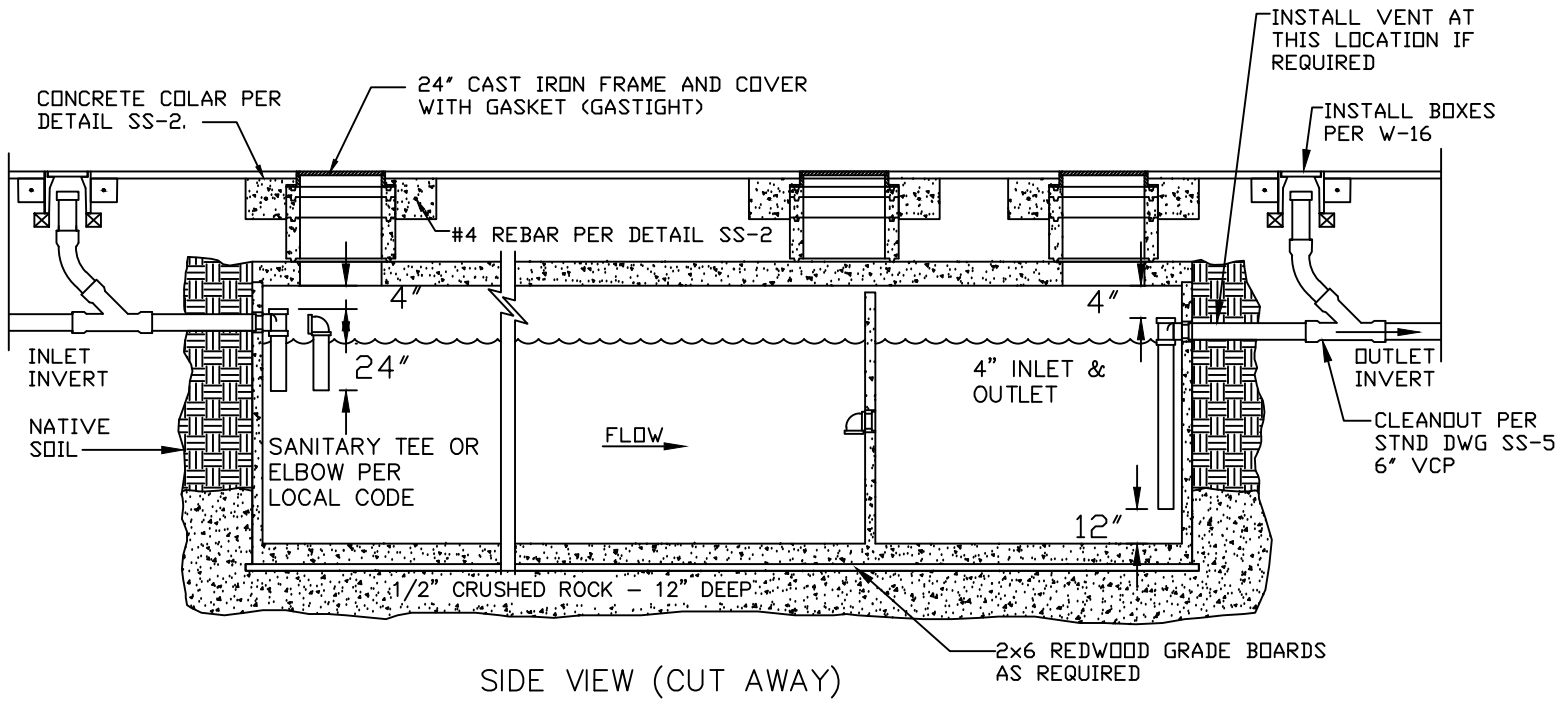

SIDE VIEW (CUT AWAY)

MIN. BOX DESIGN LOAD: H-20 TRAFFIC

Richard D. Plecker

RICHARD PLECKER
ENVIRONMENTAL UTILITIES DIRECTOR

*NOTE: THE PRECAST CONCRETE UNITS SHALL BE PLACED ON LEVEL UNDISTURBED SOIL, W/1/2" CRUSHED ROCK 12" DEEP. TWO 2x6 REDWOOD GRADE BOARDS SHALL BE PLACED BELOW THE TANK SIDE WALLS ALONG THE LONG DIMENSION PER THR MANUFACTURERS GUIDELINES.

SIZING SHALL BE BASED ON CALIFORNIA PLUMBING CODE

*NOTE: PRIOR TO BACKFILL, INTERCEPTOR SHALL BE FILLED WITH WATER AND HELD FOR 24HRS WITH NO VISIBLE LEAKAGE.

*NOTE: IF SIZE IS <1000 GAL, INTERCEPTOR DOES NOT HAVE MIDDLE MANHOLE



ENVIRONMENTAL UTILITIES
DEPARTMENT

SAND/OIL INTERECEPTOR

SCALE: NONE
REVISED: JANUARY 2017
DRAWN BY: R. VAN NESS
APPROVED BY: RICHARD PLECKER

SS-7

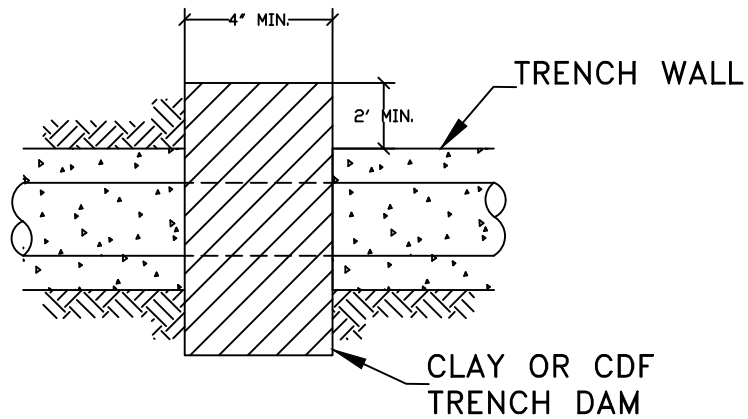

PLAN VIEW

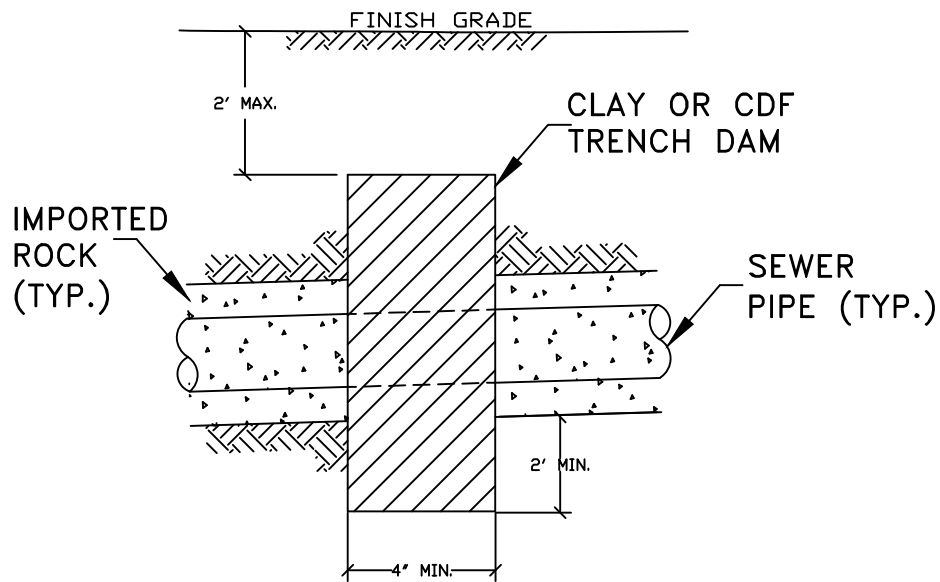

PROFILE VIEW

NOTE:

TRENCH DAM SHALL BE CONSTRUCTED OF CLEAN CLAY MATERIAL OR CONTROLLED DENSITY FILL.

Richard D. Plecker

RICHARD PLECKER
ENVIRONMENTAL UTILITIES DIRECTOR



ENVIRONMENTAL UTILITIES
DEPARTMENT

TRENCH DAM

SCALE: NONE
REVISED: JANUARY 2016
DRAWN BY: R. VAN NESS
APPROVED BY: RICHARD PLECKER

SS-8

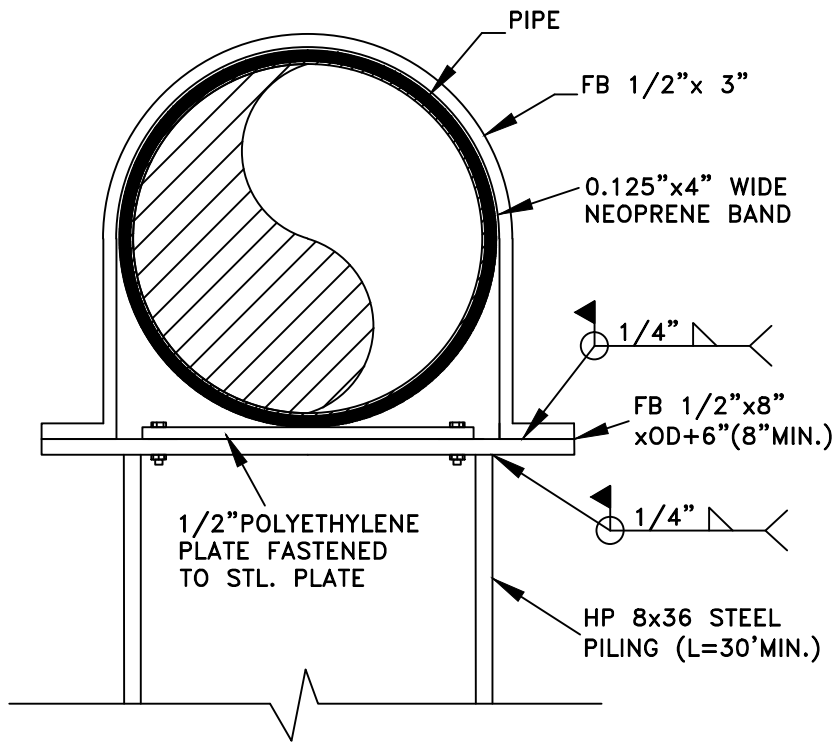

PIPE SUPPORT DETAIL

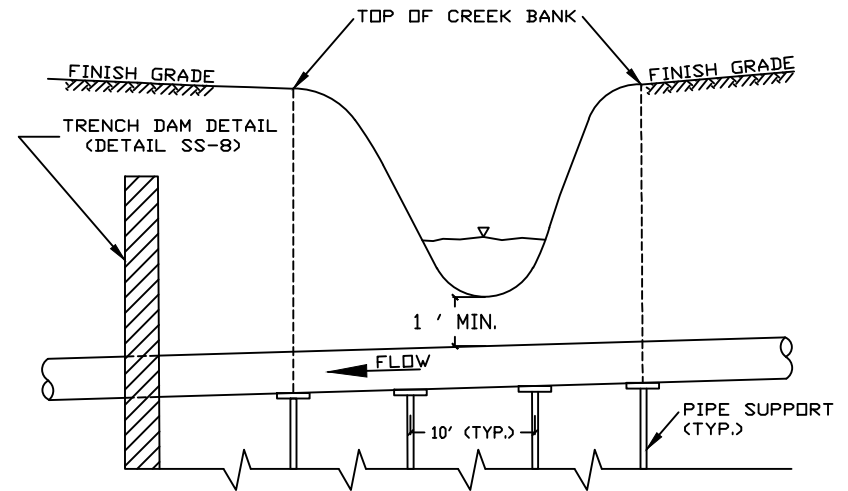

CREEK CROSSING

Richard D. Plecker

RICHARD PLECKER
ENVIRONMENTAL UTILITIES DIRECTOR

MTRL. NOTES:

1. STRUCTURAL STL. SHALL BE A36 (Fy=36ksi)
2. WELDING RODS SHALL BE E70 (Fy=70ksi)

DESIGN NOTES:

1. PILES SHALL BE 10' ON CENTER BEGINNING AND ENDING AT CREEK BOTH SIDES "TOP OF BANK" AND AS NOTED ON THE PROJECT PLANS.

	ENVIRONMENTAL UTILITIES DEPARTMENT
	CREEK CROSSING SUPPORT
SCALE: NONE REVISED: JANUARY 2016 DRAWN BY: R. VAN NESS APPROVED BY: RICHARD PLECKER	SS-9

NOTES

1. MANHOLE LID SHALL BE SEALED WITH AN APPROVED RUBBER GASKET.
2. JOINTS SHALL BE MORTARED INSIDE AND OUT.
3. APPLY EPOXY COATING TO INTERIOR SURFACES OF MANHOLE IN ACCORDANCE WITH CITY STANDARDS 91-10 K.
4. PROVIDE SPARK TEST OVER ENTIRE PROTECTIVE COATINGS AFTER INSTALLATION.
5. SEE STANDARD DETAIL SS-2 FOR ADDITIONAL REQUIREMENTS.

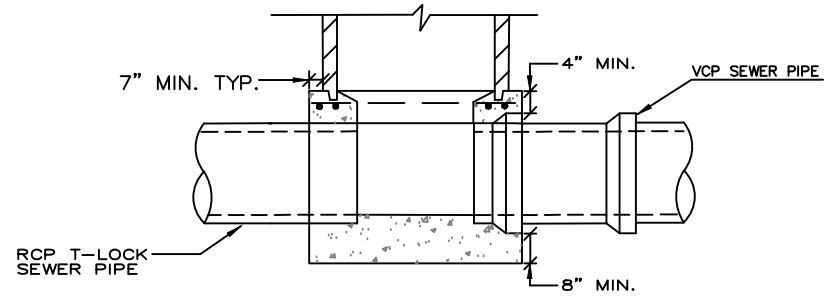
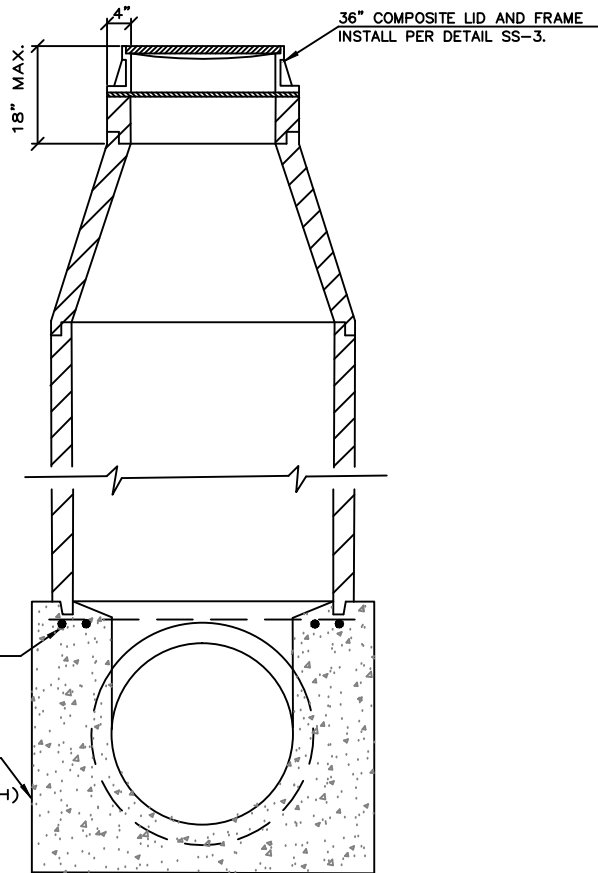

PROFILE

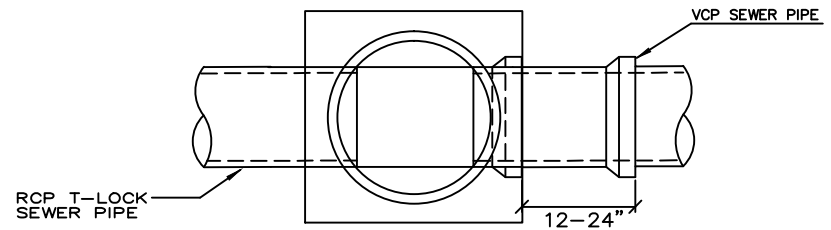

PLAN

Richard D. Plecker

RICHARD PLECKER
ENVIRONMENTAL UTILITIES DIRECTOR



ENVIRONMENTAL UTILITIES
DEPARTMENT

**60"+ SEWER TRUNK MAIN
MANHOLE**

SCALE: NONE
REVISED: JANUARY 2016
DRAWN BY: R. VAN NESS
APPROVED BY: RICHARD PLECKER

SS-10

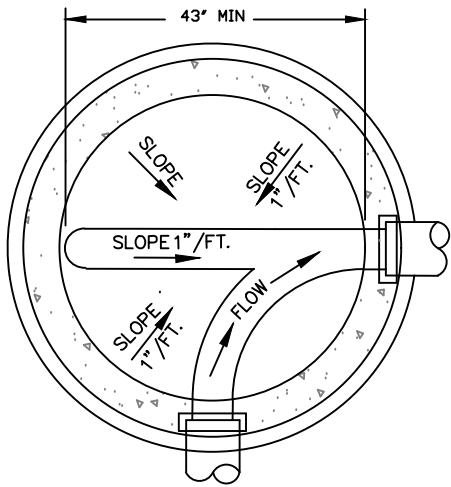

PLAN

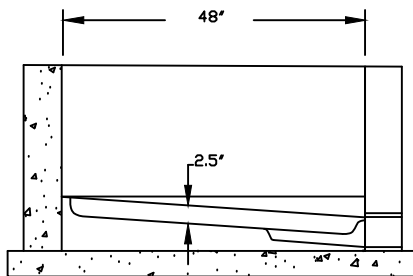
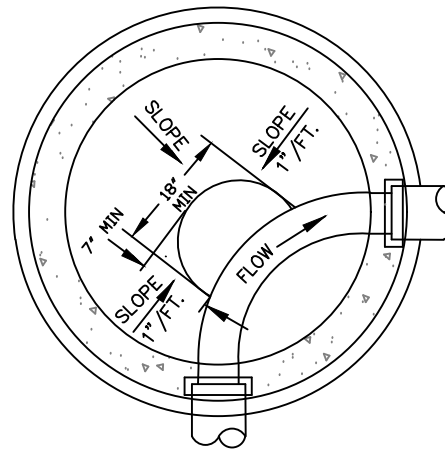

ELEVATION

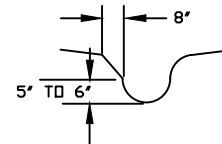

FOR 8' PIPE BASE

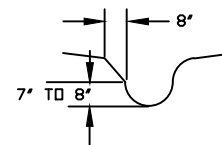

FOR 10' PIPE BASE

Richard D. Plecker

RICHARD PLECKER
ENVIRONMENTAL UTILITIES DIRECTOR

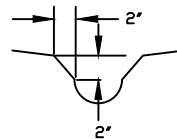
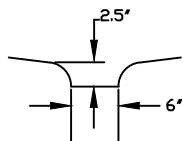

CITY OF
ROSEVILLE
CALIFORNIA

ENVIRONMENTAL UTILITIES
DEPARTMENT

**CAMERA CHANNEL
MANHOLE**

SCALE: NONE
REVISED: JANUARY 2018
DRAWN BY: R. VAN NESS
APPROVED BY: RICHARD PLECKER

SS-11

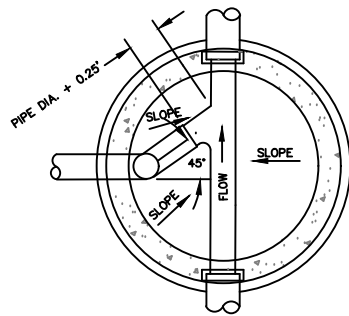

PLAN

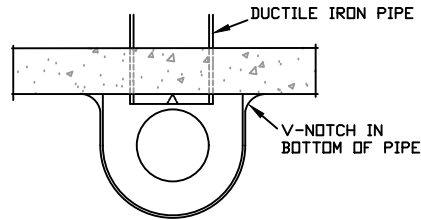

DROP BOWL
MOUNTING POSITION
TOP VIEW

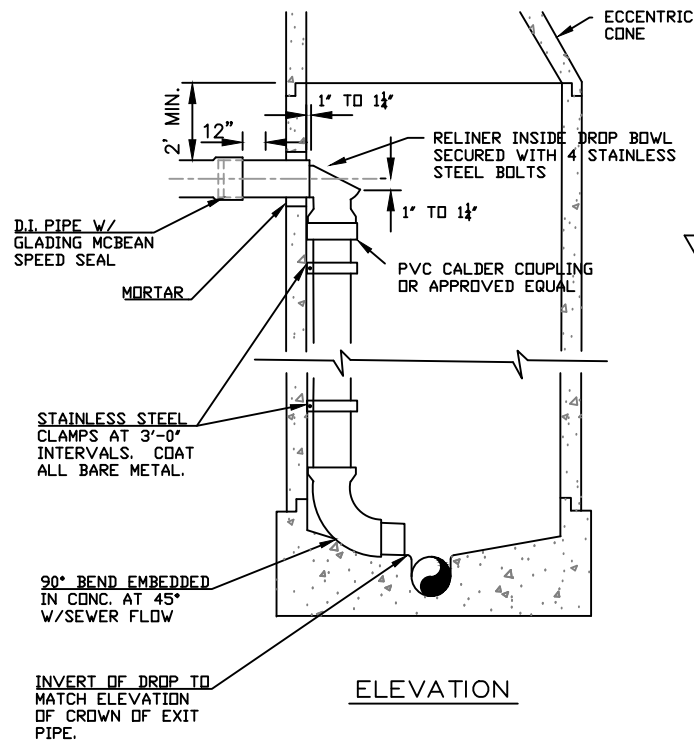

ELEVATION

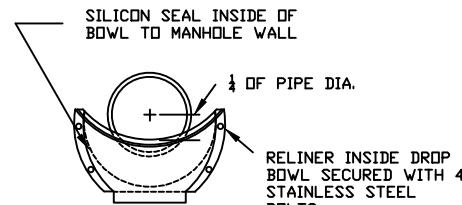

DROP BOWL
MOUNTING POSITION
FRONT VIEW

NOTES

1. INSIDE DROP PIPING SHALL BE P.V.C. PIPE, SCHEDULE 40.
2. PRIME AND CEMENT ALL JOINTS AS RECOMMENDED BY THE MANUFACTURER.
3. DROP CONNECTION PIPE & FITTINGS TO BE SAME SIZE AS ENTERING PIPE.
4. USE ECCENTRIC CONE WITH OPENING ALIGNED ABOVE DROP CONNECTION.
5. INSIDE DROP CONNECTION SHALL USE DROP BOWL AS PRODUCED BY RELINER DURAN, INC. 53 MT ARCHER RD. LYME CT. 03671 (860)434-0277 FAX: (860)434-3195 OR APPROVED EQUAL
6. ATTACH DROP BOWL & EACH CLAMPING BRACKET TO THE MANHOLE WALL WITH STAINLESS STEEL $\frac{3}{8}$ " X $\frac{3}{4}$ " RAMSET/RED HEAD BOLTS. PRE-ROTO DRILL AND SET BOLTS IN PLACE WITH EPOXY PASTE. EPOXY PASTE SHALL MEET THE FOLLOWING REQUIREMENTS:
 - A. EPOXY PASTE SHALL BE A TWO COMPONENT 100% SOLID SYSTEM. EPOXY SHALL BE SIKADUR 31 HI-MOD GEL BY SIKA CORPORATION PHONE (592) 941-0231 OR EQUAL.
 - B. THE EPOXY PASTE SHALL DEVELOP A MINIMUM COMPRESSIVE STRENGTH OF 5,000 PSI IN 28 DAYS WHEN TESTED IN ACCORDANCE WITH ATSM D695 AT 73 DEGREES.
 - C. THE EPOXY PASTE SHALL DEVELOP A MINIMUM TENSILE STRENGTH OF 3,000 PSI IN 14 DAYS WHEN TESTED IN ACCORDANCE WITH ATSM D638.
 - D. THE EPOXY PASTE SHALL DEVELOP A MINIMUM BOND STRENGTH OF 2,000 PSI IN 2 DAYS WHEN TESTED IN ACCORDANCE WITH ATSM C882 (HARDENED CONCRETE TO HARDENED CONCRETE).
 - E. MANUFACTURER'S INSTRUCTION SHALL BE PRINTED ON EACH CONTAINER IN WHICH THE MATERIALS ARE PACKAGED.
 - F. DROP BOWL MODEL "A-4" SHALL BE USED FOR ALL LINES UP THROUGH FULL 6" INLETS. DROP BOWL MODEL "A-6" SHALL BE USED FOR ALL 8" INLETS. DROP BOWL MODEL "B-8" SHALL BE USED FOR ALL 10" INLETS. DROP BOWL MODEL "B-10" SHALL BE USED FOR ALL 12" INLETS.

Richard D. Plecker

RICHARD PLECKER
ENVIRONMENTAL UTILITIES DIRECTOR



ENVIRONMENTAL UTILITIES
DEPARTMENT

INSIDE DROP
CONNECTION

SCALE: NONE
REVISED: JANUARY 2020
DRAWN BY: D. SAMUELSON
APPROVED BY: RICHARD PLECKER

SS-12